



## B-Box 2.5 - 10.0 B-Plus 2.5



### The battery for all applications

- From 2.5 to 80 kWh
- Flexible 2.5 kWh module
- Emergency-backup through high discharge power
- 1 and 3 phase systems
- Upgrade anytime
- Lithium iron phosphate battery: Maximum safety, cycle-stability and power

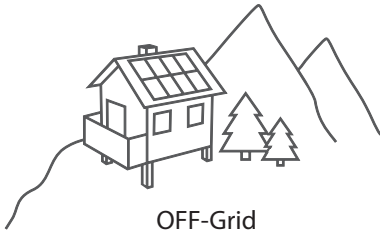

OFF-Grid



Self-consumption optimization

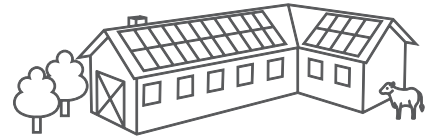

Commercial applications

### B-Box 2.5 to B-Box 10.0



- Flexible combination of capacity
- Modular design simplifies transport and installation (19" plug-in units)

The BYD B-Box is a lithium iron phosphate (LiFePO<sub>4</sub>) battery unit with battery management system (BMS) for usage with an external inverter. Thanks to its modular design B-Box grows with its requirements.:

- **B-Box 2.5** (2.56 kW / 2.45 kWh)
- **B-Box 5.0** (5.12 kW / 4.9 kWh)
- **B-Box 7.5** (7.68 kW / 7.35 kWh)
- **B-Box 10.0** (10.24 kW / 9.8 kWh)

All systems can be extended with the battery modules **B-Plus 2.5** at any time. This way in parallel connection up to 10 kWh (9.8 kWh usable) per cabinet and 80 kWh in 8 cabinets (78.4 kWh usable) are possible.

### B-Plus 2.5



- CE and TÜV certified BYD B-Plus 2.5 module (U3A1-50P-A)
- Proven and tested in telecommunications and energy storage applications worldwide
- Environment-friendly, high-performance LiFePO<sub>4</sub> battery technology

## Dimensions

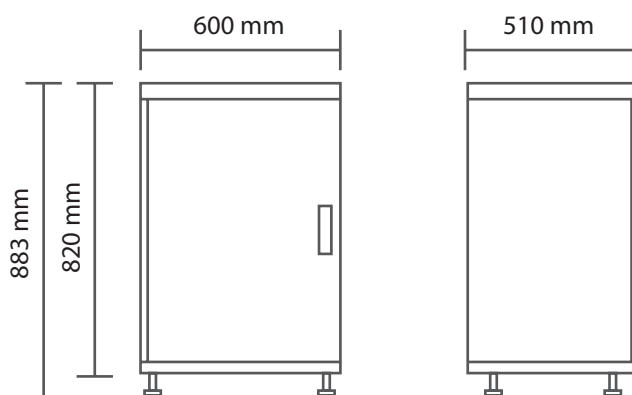

## Technical parameters



	B-Box 2.5	B-Box 5.0	B-Box 7.5	B-Box 10.0	B-Plus 2.5
Battery type	Lithium iron phosphate (LiFePO <sub>4</sub> )				
Battery configuration	1 x B-Plus 2.5 (50 Ah; 51.2 V)	2 x B-Plus 2.5 (50 Ah; 51.2 V)	3 x B-Plus 2.5 (50 Ah; 51.2 V)	4 x B-Plus 2.5 (50 Ah; 51.2 V)	Battery module 50 Ah; 51.2 V
Nominal capacity	2.56 kWh	5.12 kWh	7.68 kWh	10.24 kWh	2.56 kWh
Usable capacity <sup>1</sup>	2.45 kWh	4.9 kWh	7.35 kWh	9.8 kWh	2.45 kWh
Max output power	2.56 kW	5.12 kW	7.68 kW	10.24 kW	2.56 kW
Peak output power, 30 sec	5.12 kW	10.24 kW	15.36 kW	20.48 kW	5.12 kW
Nominal voltage	51.2 V <sub>DC</sub>				
Voltage range	43.2 - 56.4 V				
Ambient temperature <sup>2</sup>	-10 °C to +50 °C				
Interfaces	RS485/CAN				
Round trip energy efficiency	≥ 95.3 %				
Warranty	10 years				
Certifications and standards	UL1642 for cell, TÜV and CE for battery module, EMC (EN 61 000 chapter 4.2, 4.3, 4.5, 4.6; EN55022), dangerous goods (UN3480, UN38.3) Safety Guidelines - Li-ion Home Battery Storage Systems, Version 1.0E (TÜV)				
IP protection class	IP 20				
Dimensions (W/D/H)	600 x 510 x 883 mm				483 x 490 x 130 mm
Weight	79 kg	113 kg	146 kg	180 kg	34 kg
Compatible inverters	SMA / Goodwe / Solax / Victron, updated list on: <a href="http://www.eft-systems.de">www.eft-systems.de</a>				
Scalable	Extend anytime / up to 8 systems parallel / 80 kWh (78.4 kWh usable)				

[1] Test Conditions: 0.25C discharge @+25°C

[2] -10°C to 12°C will be derating

Your energy storage expert:

BYD  
BYD Company Limited  
[www.byd.com/energy](http://www.byd.com/energy)  
E-Mail: [bydbbox@byd.com](mailto:bydbbox@byd.com)

BYD B-BOX EU Service Partner  
EFT-Systems GmbH  
[www.eft-systems.de](http://www.eft-systems.de)  
info@eft-systems.de